

DATA SHEETS

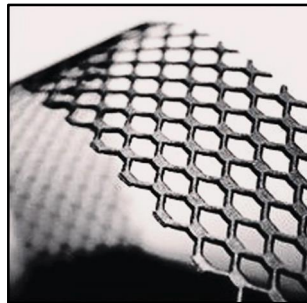
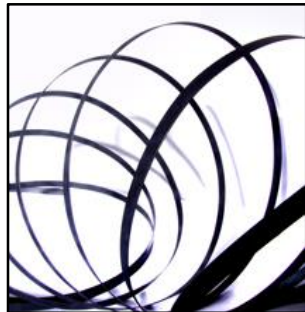

MIXED METAL OXIDE ANODES FOR CATHODIC PROTECTION APPLICATIONS

USA OFFICE : PHONE 281 498 4727 FAX 281 498 4728 TOLL FREE 877 483 5776

UK OFFICE : PHONE 44 1453 845 718 FAX 44 1453 845 719

WEB : WWW.TELPROCOMPANIES.COM

EMAIL : MASH@TELPROCOMPANIES.COM / CATHY@TELPROCOMPANIES.COM / ANDREW@TELPROCOMPANIES.COM

TELPRO TUBULAR ANODES DATA SHEET



Titanium Electrode Products Companies, "TELPRO," are manufacturers of mixed metal oxide anodes for cathodic protection.

TELPRO Tubular Anodes are manufactured using titanium, which meets ASTM B338 Grade 1 or Grade 2 standards, which has been coated with **TELPRO Mixed Metal Oxide** coating.

TELPRO MMO coating consists of IrO₂/Ta₂O₅ and is suitable for use in all cathodic protection applications. Because mixed metal oxide anodes have an extremely low consumption rate, the titanium substrate remains constant throughout the design life of the anode.

Based upon accelerated life testing, conducted by an independent laboratory, **TELPRO MMO** coating has been proven to be equivalent or superior to other mixed metal oxide coatings which are currently being used; a copy of this test report is available upon request.

APPLICATIONS
CANISTERED ANODES
ABOVE GROUND STORAGE TANKS
UNDERGROUND STORAGE TANKS
WATER STORAGE TANKS
HORIZONTAL GROUNDBEDS
TUBULAR AND SHEET PILES
VERTICAL GROUNDBEDS
DEEP WELL ANODE GROUNDBEDS

Strict quality control procedures are followed throughout the entire coating process, to guarantee proper coating adhesion and loading. Also, **TELPRO** products are tested using an X-Ray Fluorescence Spectrometer, to ensure production of the highest quality product, which is fundamental in every step of the manufacturing process.

PERFORMANCE DATA AND RATINGS

COKE, SOIL AND FRESH WATER	CURRENT OUTPUT	DESIGN LIFE
3/4" x 48" (19mm x 1,220mm)	7 Amps	20 years
1" x 19.7" (25mm x 500mm)	4 Amps	20 years
1" x 39.4" (25mm x 1,000mm)	8 Amps	20 years
1" x 48" (25mm x 1,220mm)	3.5 Amps *	20 years
1" x 60" (25mm x 1,500mm)	4.5 Amps *	20 years
1.25" x 48" (32mm x 1,220mm)	12 Amps	20 years

* Current outputs are de-rated for use in metallurgical coke breeze - 50Am²

USA OFFICE : PHONE 281 498 4727 FAX 281 498 4728 TOLL FREE 877 483 5776

UK OFFICE : PHONE 44 1453 845 718 FAX 44 1453 845 719

WEB : WWW.TELPROCOMPANIES.COM

EMAIL : MASH@TELPROCOMPANIES.COM / CATHY@TELPROCOMPANIES.COM / ANDREW@TELPROCOMPANIES.COM

TELPRO TUBULAR ANODES DATA SHEET

SEAWATER	CURRENT OUTPUT	DESIGN LIFE
3/4" x 48" (19mm x 1,220mm)	45 Amps	20 years
1" x 19.7" (25mm x 500mm)	25 Amps	20 years
1" x 39.4" (25mm x 1,000mm)	50 Amps	20 years
1.25" x 48" (32mm x 1,220mm)	75 Amps	20 years
ENVIRONMENT	MAX CURRENT DENSITY	LIFETIME
CARBONACEOUS BACKFILL	4.6A/ft ² (50A/m ²)	20 years
CALCINED PETROLEUM BACKFILL	9.3A/ft ² (100A/m ²)	20 years
FRESHWATER	9.3A/ft ² (100A/m ²)	20 years
BRACKISH WATER	9.3-27.8A/ft ² (100-300A/m ²)	20 years
SEAWATER	55.8A/ft ² (600A/m ²)	20 years

Lifetimes stated are nominal, we can supply Amps / life different to stated standards on request

TYPICAL APPLICATIONS FOR TUBULAR ANODES

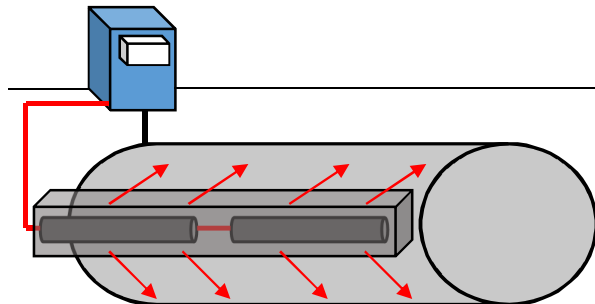

HORIZONTAL GROUNDBEDS

PROTECTION OF CROSS COUNTRY PIPELINES

ANODES TYPICALLY INSTALLED IN A TRENCH WITH
COKE BACKFILL

IDEAL FOR AREAS OF LOW RESISTIVITY / NO ACCESS /
R.O.W. ISSUES

DEEPWELL GROUND BEDS

PROTECTION OF PIPELINES / WELL CASINGS

ANODES INSTALLED IN COKE BREEZE COLUMN OR
BELOW WATER TABLE LEVEL

USED IN AREAS OF HIGH SURFACE RESISTIVITY
AND/ OR ACCESS / R.O.W. LIMITATIONS

ACTIVE WELL AREA LINED WITH PERFORATED CASING

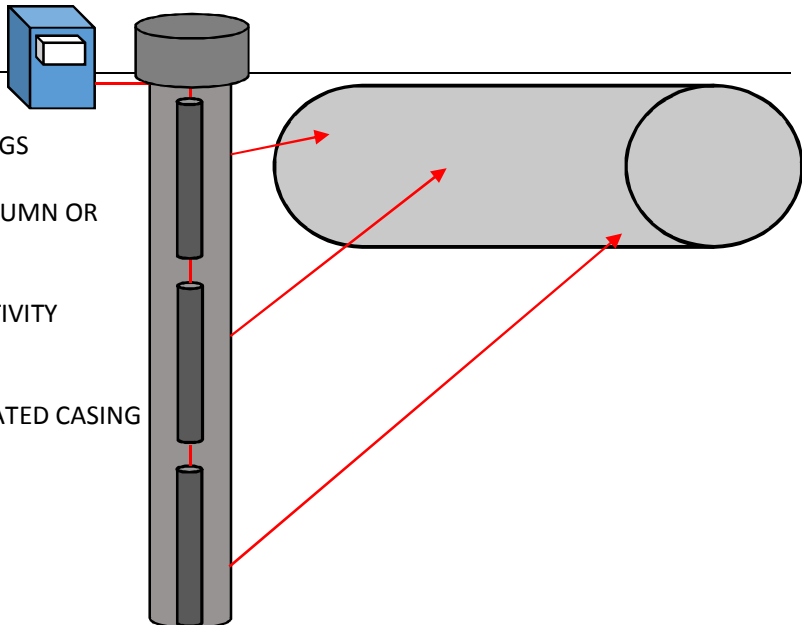

TELPRO DEEP WELL ANODES DATA SHEET

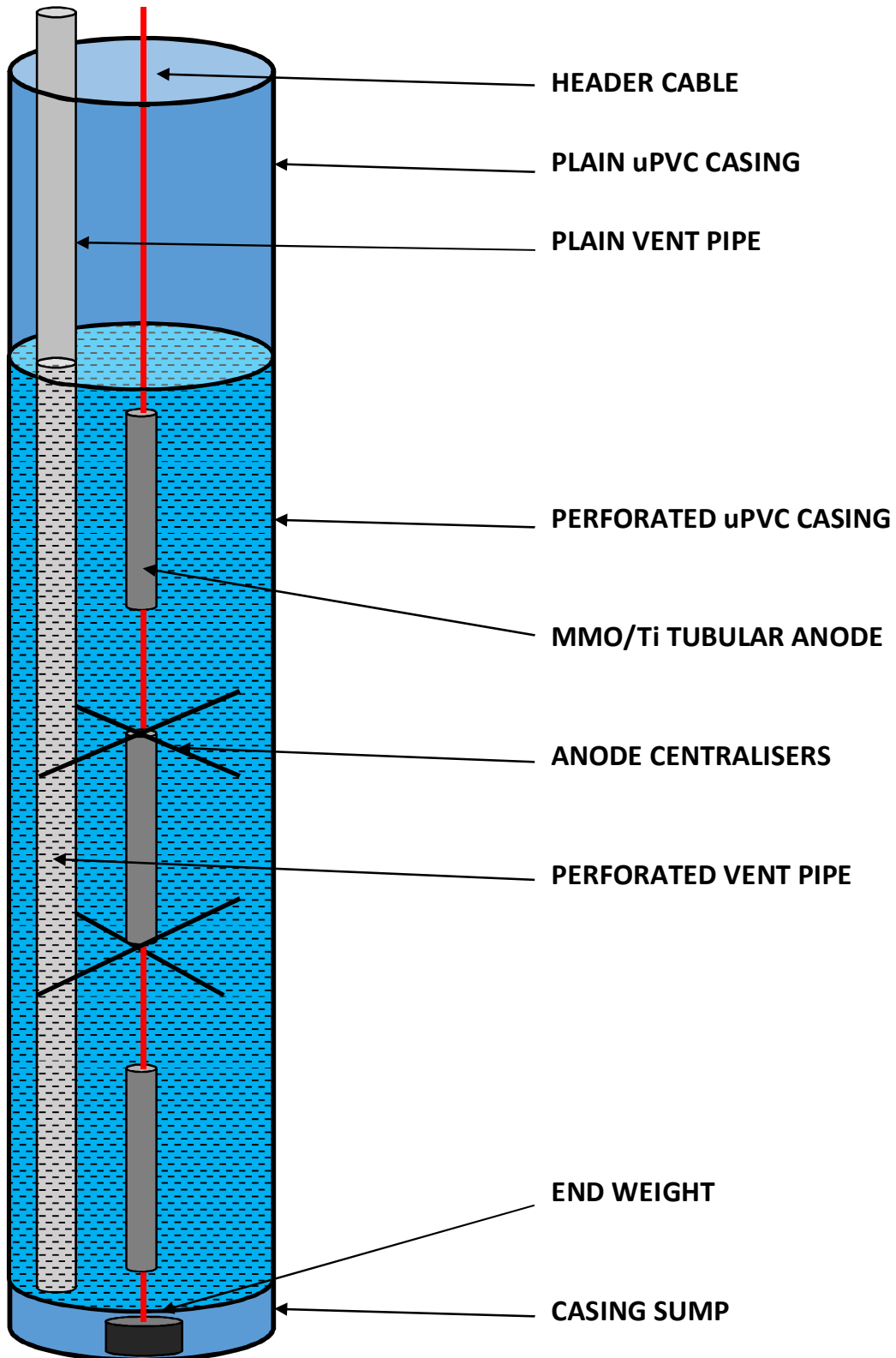

TELPRO RIBBON ANODES DATA SHEET

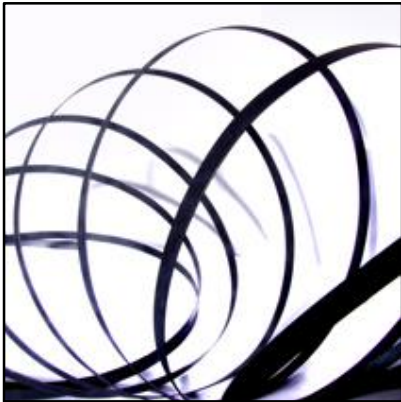

Titanium Electrode Products Companies, "TELPRO," are manufacturers of mixed metal oxide anodes for cathodic protection.

TELPRO Ribbon Anodes are manufactured using solid titanium, which meets ASTM B265 Grade 1 or Grade 2 standards, which has been coated with **TELPRO** Mixed Metal Oxide coating.

TELPRO MMO coating consists of IrO₂/Ta₂O₅ and is suitable for use in all cathodic protection applications. Because mixed metal oxide anodes have an extremely low consumption rate, the titanium substrate remains constant throughout the design life of the anode.

Based upon accelerated life testing, conducted by an independent laboratory, **TELPRO MMO** coating has been proven to be equivalent or superior to other mixed metal oxide coatings which are currently being used; a copy of this test report is available upon request.

APPLICATIONS

ABOVE GROUND STORAGE TANK BASES

STEEL REBAR IN CONCRETE

LINEAR FLEX ANODE FOR INPLANT PIPEWORK

Strict quality control procedures are followed throughout the entire coating process, to guarantee proper coating adhesion and loading. Also, **TELPRO** products are tested using an X-Ray Fluorescence Spectrometer, to ensure production of the highest quality product, which is fundamental in every step of the manufacturing process.

MMO RIBBON ANODE SPECIFICATIONS

COATING :	IRIDIUM BASED MIXED METAL OXIDE
SUBSTRATE :	TITANIUM ASTM B265 Gr1
NOMINAL DIMENSIONS:	0.25" (6.35mm) Wide X 0.025" (0.635mm) Thick
COIL LENGTH :	328ft (100m)
COIL WEIGHT :	3.5 lbs (1.6 Kgs)
SURFACE AREA :	0.014m ² /m
RESISTANCE :	0.042 ohms/ft

USA OFFICE : PHONE 281 498 4727 FAX 281 498 4728 TOLL FREE 877 483 5776

UK OFFICE : PHONE 44 1453 845 718 FAX 44 1453 845 719

WEB : WWW.TELPROCOMPANIES.COM

EMAIL : MASH@TELPROCOMPANIES.COM / CATHY@TELPROCOMPANIES.COM / ANDREW@TELPROCOMPANIES.COM

TELPRO RIBBON ANODES DATA SHEET

CURRENT OUTPUT OF RIBBON IN FINE SAND

12.8mA/ft (42mA/m) When operating at an anode current density of 0.278A/ft² (3A/m²)

DESIGN LIFE

50 years plus when operating at an anode current density of 0.278A/ft² (3A/m²)

Lifetimes stated are nominal, we can supply Amps / life different to stated standards on request.

CURRENT OUTPUT OF RIBBON IN CONCRETE

0.45mA/ft (1.5mA/m) when operating at an anode current density of 10.19mA/ft² (100A/m²)

DESIGN LIFE

100 years plus when operating at an anode current density of 10.19mA/ft² (100A/m²)

Lifetimes stated are nominal, we can supply Amps / life different to stated standards on request.

NOMINAL DIMENSIONS OF TITANIUM CONDUCTOR BAR

MATERIAL :	TITANIUM ASTM B265 Gr1
DIMENSIONS :	0.50" (12.7mm) Wide x 0.035" (0.9mm) Thick
COIL LENGTH :	328ft (100m)
COIL WEIGHT :	11 lbs (5kgs)

TYPICAL APPLICATIONS FOR RIBBON ANODES

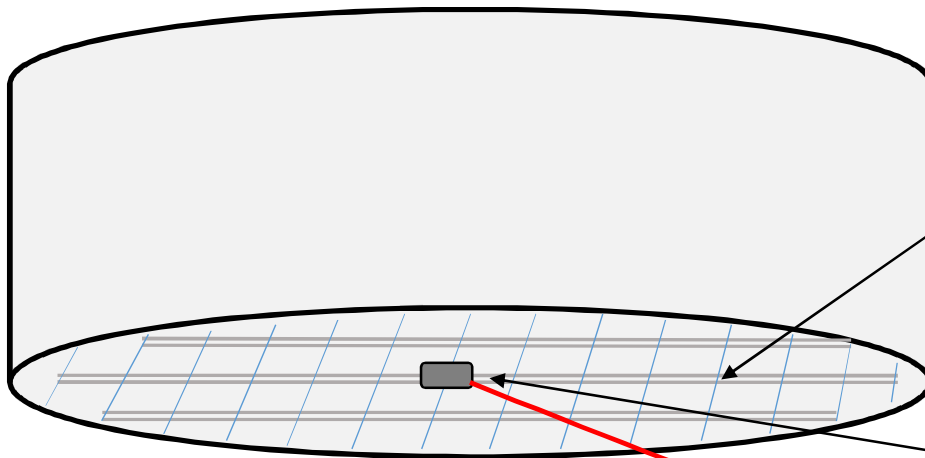

UNDERTANK GRID SYSTEM LAYOUT – MMO/Ti RIBBON / Ti CONDUCTOR BAR FOR EXTERNAL BASE PLATE PROTECTION.

- RELIABLE
- ECONOMICAL
- EASY TO INSTALL
- EXTENSIVE WORLDWIDE TRACK RECORD

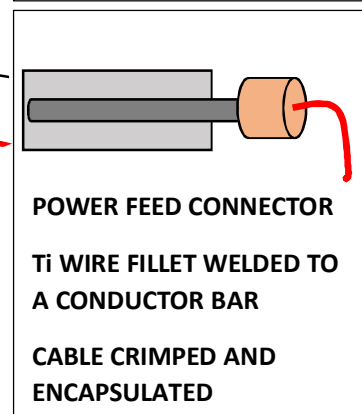
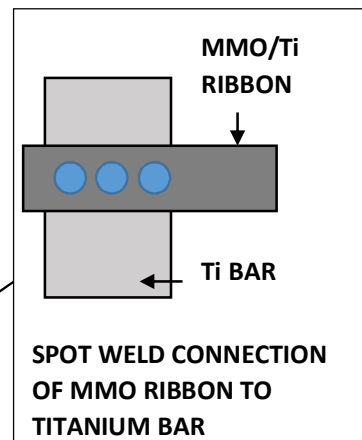



**MANUFACTURERS OF MMO AND
PLATINIZED TITANIUM ELECTRODES**

TELPRO WIRE ANODES DATA SHEET



Titanium Electrode Products Companies, "TELPRO," are manufacturers of mixed metal oxide anodes for cathodic protection.

TELPRO Wire Anodes are manufactured using solid titanium, which meets ASTM B863 Grade 1 or Grade 2 standards, which has been coated with **TELPRO** Mixed Metal Oxide coating.

TELPRO MMO coating consists of IrO₂/Ta₂O₅ and is suitable for use in all cathodic protection applications. Because mixed metal oxide anodes have an extremely low consumption rate, the titanium substrate remains constant throughout the design life of the anode.

TELPRO MMO Wire Anodes are available in two standard sizes, with two standard current output ratings. Other sizes and current output ratings are available upon request. Based upon accelerated life testing, conducted by an independent laboratory, **TELPRO MMO** coating has been proven to be equivalent or superior to other mixed metal oxide coatings which are currently being used; a copy of this test report is available upon request.

APPLICATIONS
CANISTERED ANODES
ABOVE GROUND STORAGE TANKS
UNDERGROUND STORAGE TANKS
WATER STORAGE TANKS
CONTINUOUS HORIZONTAL GROUNDBEDS
SHALLOW VERTICAL GROUNDBEDS
NATURAL WATER
DEEPANODE GROUNDBEDS

Strict quality control procedures are followed throughout the entire coating process, to guarantee proper coating adhesion and loading. Also, **TELPRO** products are tested using an X-Ray Fluorescence Spectrometer, to ensure production of the highest quality product, which is fundamental in every step of the manufacturing process.

PERFORMANCE DATA AND RATINGS

ELECTROLYTE	MAXIMUM CURRENT DENSITY	LIFETIME
SOIL	4.6 A/ft ² (50A/m ²)	20 YEARS
CARBONACEOUS BACKFILL	9.3 A/ft ² (100A/m ²)	20 YEARS
FRESHWATER	9.3 A/ft ² (100A/m ²)	20 YEARS
BRACKISH WATER **	9.3 - 27.8 A/ft ² (100 - 300A/m ²)	20 YEARS
SEAWATER	55.8 A/ft ² (600A/m ²)	20 YEARS
Coating loading can be increased or decreased depending on particular life / current density requirements		
** Current Density should be determined in accordance with brackish water resistivity		

USA OFFICE : PHONE 281 498 4727 FAX 281 498 4728 TOLL FREE 877 483 5776

UK OFFICE : PHONE 44 1453 845 718 FAX 44 1453 845 719

WEB : WWW.TELPROCOMPANIES.COM

EMAIL : MASH@TELPROCOMPANIES.COM / CATHY@TELPROCOMPANIES.COM / ANDREW@TELPROCOMPANIES.COM

TELPRO WIRE ANODES DATA SHEET

TELPRO WIRE ANODES CURRENT RATING IN CALCINED PETROLEUM COKE :

0.062" (1.5mm) - 200mA/linear ft (656mA/linear m)

0.125" (3.175mm) - 400mA/linear ft (1,312mA /linear m)

BASED ON 20 YEAR DESIGN LIFE

Lifetimes stated are nominal, we can supply Amps / life different to stated standards on request.

TYPICAL APPLICATIONS FOR WIRE ANODES

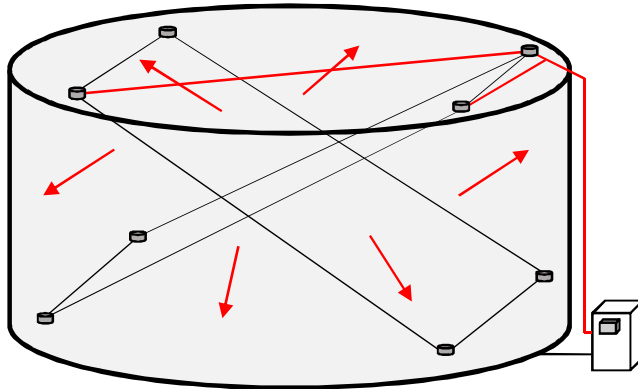

SUSPENDED MMO WIRE ANODES FOR TANK INTERNAL PROTECTION

ANODES SUSPENDED / SECURED THROUGH EYEBOLTS
IN TANK FLOOR / ROOF

ANODE WIRE RATING DETERMINED BY LIFE /
ELECTROLYTE / TEMPERATURE FACTORS

EXTERNAL BOTTOM PLATE PROTECTION

UNDERTANK SYSTEM LAYOUT – CONCENTRIC WIRE /
PIGGYBACK ANODE LOOPS

CAN OFFER GREATER CONTROL OF CP SYSTEM AND NO
EXPOSED WELDING OF Ti BAR / ANODES

EASY TO INSTALL WITH PRE-CUT LENGTHS OF WIRE

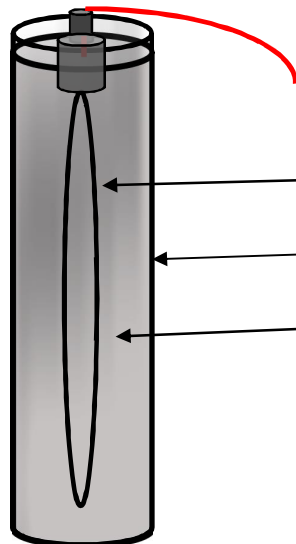
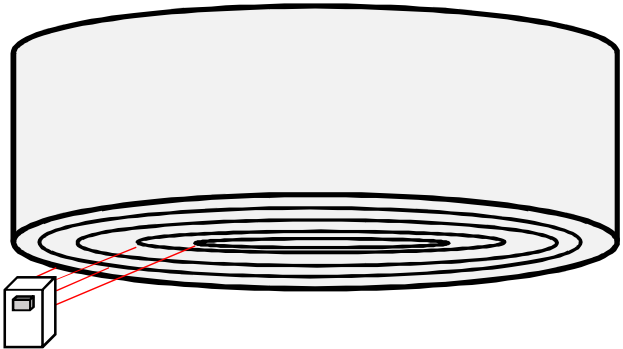

ALTERNATIVE TO TUBULAR ANODES

WIRE ANODE

GALVANISED STEEL CANISTER

COKE BREEZE BACKFILL

IDEAL FOR DISTRIBUTED ANODE SYSTEMS IN
CONGESTED PLANT AREAS.

RIBBON MESH ANODES DATA SHEET

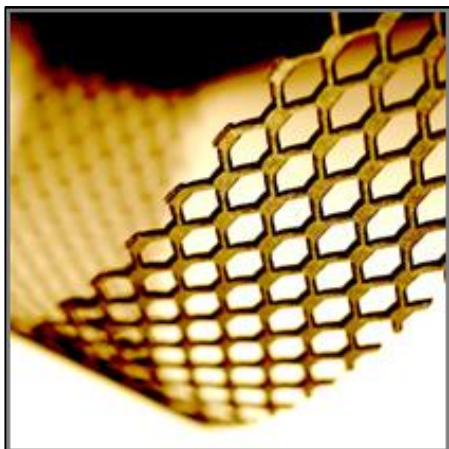

Titanium Electrode Products Companies, "TELPRO," are manufacturers of mixed metal oxide anodes for cathodic protection.

TELPRO RIBBON MESH Anodes are manufactured using a titanium expanded mesh substrate, which meets ASTM B265 Grade 1 or Grade 2 standards, which has been coated with **TELPRO** Mixed Metal Oxide coating.

TELPRO MMO coating consists of IrO₂/Ta₂O₅ and is suitable for use in all cathodic protection applications. Because mixed metal oxide anodes have an extremely low consumption rate, the titanium substrate remains constant throughout the design life of the anode.

APPLICATIONS

STEEL REBAR IN CONCRETE
CANISTER ANODES
DECAY ELECTRODES

Based upon accelerated life testing, conducted by an independent laboratory, **TELPRO MMO** coating has been proven to be equivalent or superior to other mixed metal oxide coatings which are currently being used; a copy of this test report is available upon request.

MMO RIBBON MESH ANODE SPECIFICATIONS

RIBBON MESH WIDTH	10mm	13mm	15mm	20mm
CURRENT RATING @ 110mA/m ²	2.8 mA/m	3.5 mA/m	3.9 mA/m	5.30 mA/m
EXPECTED LIFE	75 years in concrete			
CATALYST	Iridium / Tantalum Mixed Metal Oxide			
MAXIMUM ANODE / CONCRETE INTERFACE CURRENT DENSITY:				
FHWA LIMIT	110 mA/m ²	SHORT TERM LIMIT		220 mA/m ²
NOMINAL DIMENSIONS				
WIDTH	10 mm	13 mm	15 mm	20 mm
COIL LENGTH	100 m			
ANODE SURFACE PER UNIT LENGTH ANODE	0.025 m ² /m	0.032 m ² /m	0.036 m ² /m	0.0482 m ² /m
APPROX. EXPANDED THICKNESS	1.30 mm			
DIAMOND DIMENSIONS	2.5 x 4.6 x 0.6 mm			
SHIPPING WEIGHT	1.4 Kgs per	1.9 Kgs per 100m	2.85 Kgs per	3.8 Kgs per

USA OFFICE : PHONE 281 498 4727 FAX 281 498 4728 TOLL FREE 877 483 5776

UK OFFICE : PHONE 44 1453 845 718 FAX 44 1453 845 719

WEB : WWW.TELPROCOMPANIES.COM

EMAIL : MASH@TELPROCOMPANIES.COM / CATHY@TELPROCOMPANIES.COM / ANDREW@TELPROCOMPANIES.COM

RIBBON MESH ANODES DATA SHEET

SUBSTRATE				
COMPOSITION	Titanium to ASTM B265 Grade 1			
CURRENT DISTRIBUTOR				
WIDTH	12.7 mm			
THICKNESS	0.90 mm			
COIL LENGTH	100 m			
SHIPPING WEIGHT PER	5.2 Kgs			
ELECTRICAL PROPERTIES				
ANODE RIBBON MESH	0.5 Ohm/m	0.39 Ohm/m	0.375 Ohm/m	0.25 Ohm/m
CURRENT DISTRIBUTOR	0.049 Ohm/m			
Lifetimes stated are nominal, we can supply Amps / life different to stated standards on request				

Strict quality control procedures are followed throughout the entire coating process, to guarantee proper coating adhesion and loading. Also, **TELPRO** products are tested using an X-Ray Fluorescence Spectrometer, to ensure production of the highest quality product, which is fundamental in every step of the manufacturing process.

TYPICAL APPLICATIONS FOR RIBBON MESH ANODES

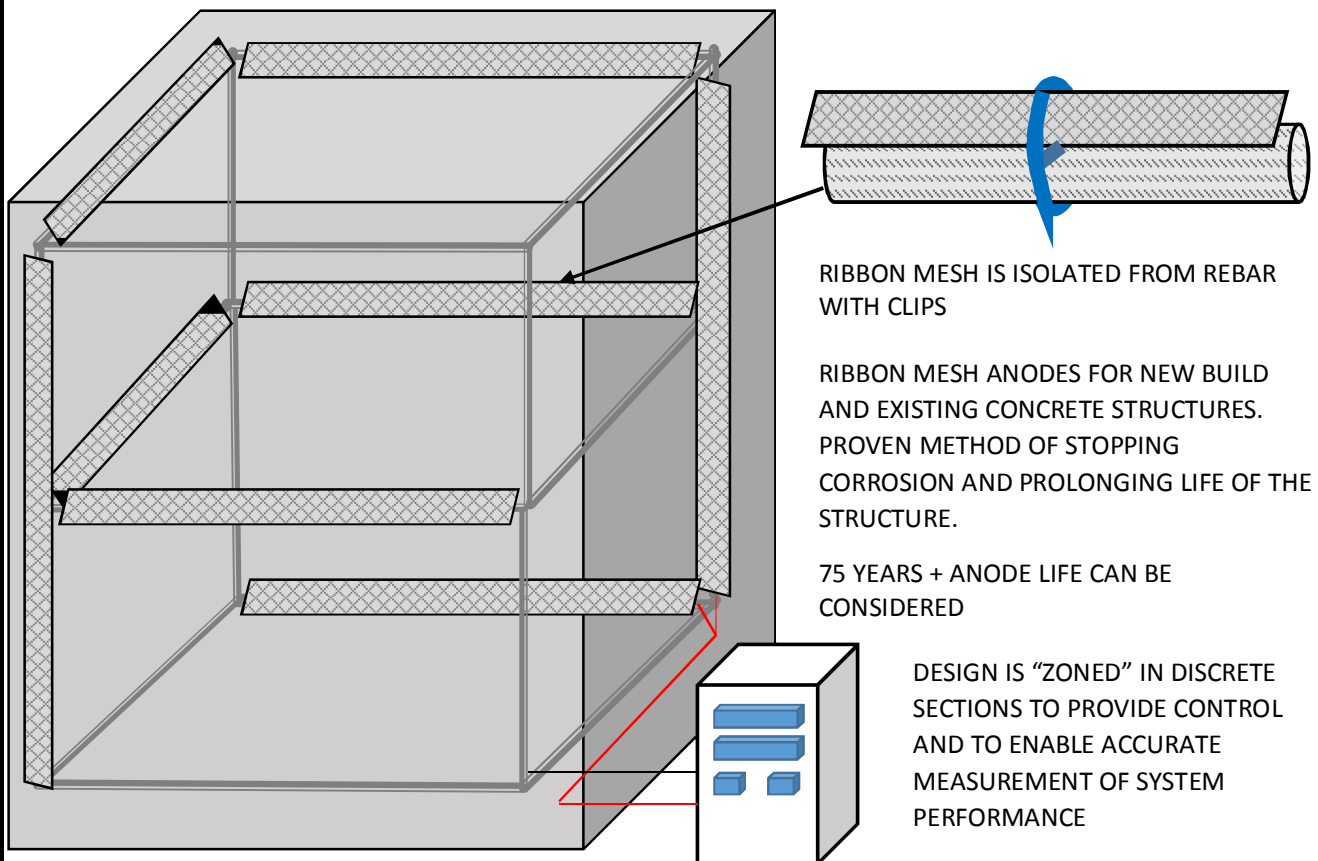

FLEX ANODES DATA SHEET



Titanium Electrode Products Companies, "TELPRO," are manufacturers of mixed metal oxide anodes for Cathodic protection.

TELPRO MMO Flex-Anodes can be assembled using **TELPRO** Wire Anodes (ASTM B348), or **TELPRO** Ribbon Anodes (ASTM B265) which have been coated with **TELPRO** Mixed Metal Oxide Coating.

TELPRO MMO coating consists of IrO₂/Ta₂O₅ and is suitable for use in all cathodic protection applications. Because mixed metal oxide anodes have an extremely low consumption rate, the titanium substrate remains constant throughout the design life of the anode.

Based upon accelerated life testing, conducted by an independent laboratory, **TELPRO MMO** coating has been proven to be equivalent or superior to other mixed metal oxide coatings which are currently being used; a copy of this test report is available upon request.

APPLICATIONS
BURIED PIPING
INPLANT PIPEWORK
VESSELS AND TANKS

Strict quality control procedures are followed throughout the entire coating process, to guarantee proper coating adhesion and loading. Also, **TELPRO** products are tested using an X-Ray Fluorescence Spectrometer, to ensure production of the highest quality product, which is fundamental in every step of the manufacturing process.

TELPRO MMO Flex-Anodes are a flexible, packaged linear anode assembly. The linear anode is packaged in a highly absorbent fabric sleeve. This sleeve is sewn using a poly four-thread double interlocking stitch, which prevents the seam from separating during installation, or when stored in high temperature conditions. The sleeve is filled using a high quality, calcined petroleum coke.

- ANODE TO CABLE CONNECTION IS RESIN FILLED AND HELIUM TESTED FOR AN EFFECTIVE SEAL OF CONNECTION
- AVAILABLE WITH OUTPUTS RANGING FROM 16mA/LIN. FT. TO 400mA/ LIN. FT.
- PACKAGED USING HIGH QUALITY CALCINED PETROLEUM COKE IN A HIGHLY ABSORBENT FABRIC SLEEVE.
- FABRIC SLEEVE IS AVAILABLE IN 1.5" to 3" DIAMETERS WITH A VARIETY OF LENGTHS AVAILABLE
- FLEXIBLE AND LIGHTWEIGHT MAKES FOR EFFICIENT INSTALLATIONS
- REDUCES REQUIREMENT FOR IN PLANT ISOLATION

USA OFFICE : PHONE 281 498 4727 FAX 281 498 4728 TOLL FREE 877 483 5776

UK OFFICE : PHONE 44 1453 845 718 FAX 44 1453 845 719

WEB : WWW.TELPROCOMPANIES.COM

EMAIL : MASH@TELPROCOMPANIES.COM / CATHY@TELPROCOMPANIES.COM / ANDREW@TELPROCOMPANIES.COM

FLEX ANODES DATA SHEET

LAYOUT OF FLEX ANODE PRODUCT

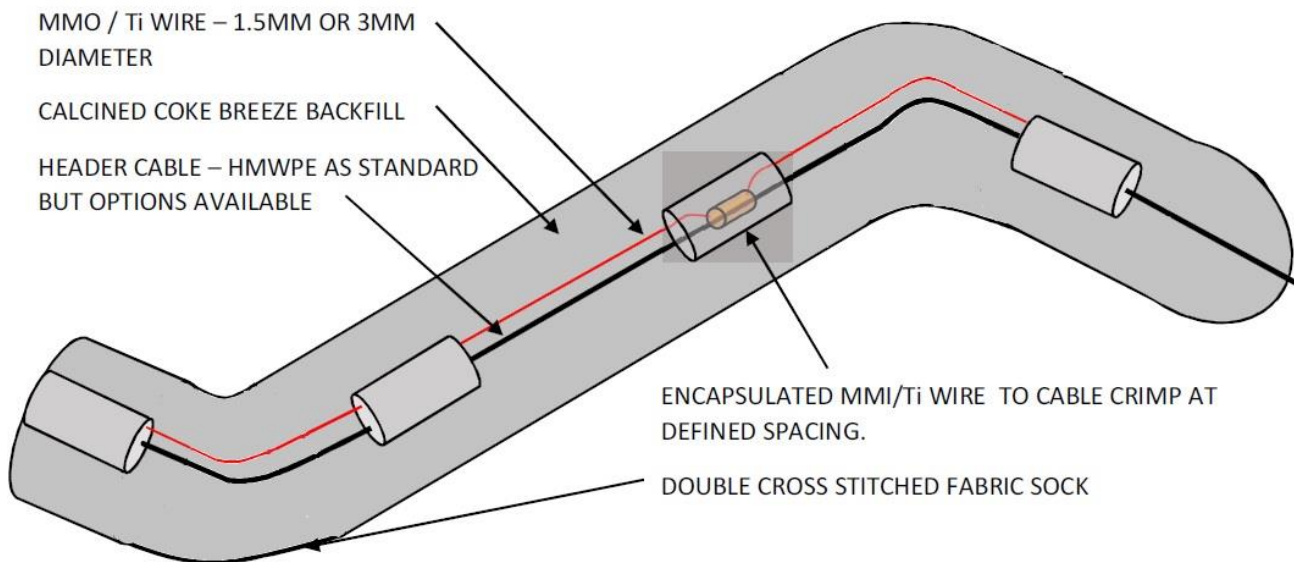

Standard Current Ratings Available (output per linear meter / linear feet)

FLEX-ANODE 52 – 52mA/m (~16mA/ft)
 FLEX-ANODE 100 – 100mA/m (~30.5mA/ft)
 FLEX-ANODE 250 – 250mA/m (~76mA/ft)
 FLEX-ANODE 400 – 400mA/m (~122mA/ft)
 FLEX-ANODE 650 – 650mA/m (~200mA/ft)

Lifetime (at full rated output) Lifetimes stated are nominal.

To be specified by client at enquiry stage or to be provided with 25 years life as standard.

Please note that FLEX-ANODES Anodes can be made according to client's custom specification. Please contact us for details stating current output required and design lifetime.

Length (per sock):

Maximum 150m c/w 1m Of Cable either end.

Backfill :

Carbonaceous Backfill

- Type: Calcined petroleum coke
- Fixed Carbon: 99.8%
- Moisture: 0.07%
- Volatile: 0.02%
- Ash: 0.1%
- Particle Size: 1.0 mm (max.)

Anode materials :

Titanium Wire MMO/Ti Wire 1.5mm or 3mm
 ASTM B863 Grade 1 Or Titanium MMO/Ti Ribbon
 nominal dimensions: 6.35mm x 0.6mm ASTM
 B265 Grade 1



**MANUFACTURERS OF MMO AND
PLATINIZED TITANIUM ELECTRODES**

Sleeve Diameter :	38mm
Anode Cable :	To client specification but as standard #8 AWG(10mm ²) HMWPE with 1m free cable tail at either end for splicing/termination.
Custom Cable	Available as per client request in HALAR/HMWPE or PVDF/HMWPE
Cable To Wire / Ribbon Connection :	Every 10m as a minimum. Note that spacing will vary dependent upon several factors such as <ul style="list-style-type: none"> • Anode used. • Cable size • Environment the Flex-Anode is placed in. Telpro can assist with design optimisation of your product.
Cable Wire / Ribbon Splice :	Proprietary technique using <ul style="list-style-type: none"> • Copper Compression Connector • Two Part Epoxy Resin • Heat – Shrink Sleeve.
Product Weight	Approx 1.5Kgs per linear m
Backfill Weight	Approx 1.15Kgs per linear m
Jacket Material & Construction	The linear anode and cable is assembled in a highly absorbent fabric sleeve. The fabric sleeve is sewn using a poly four thread double interlocking stitch, which prevents the seam from separating during installation or when stored in high temperature conditions.
Testing	<ul style="list-style-type: none"> • Anode to cable seal is resin filled and helium tested for an effective seal of the connection. • Anode to cable connection is checked for resistance. • Cable and anode are checked for electrical continuity and resistance. • MMO Coating is tested using an X-Ray Fluorescence Spectrometer to verify coating loading and adhesion.
Packing	In plywood packing cases or wooden reels ready for export/domestic shipment as required.
Marking	Each length of anode is labelled to show : <ul style="list-style-type: none"> • Section Lengths (if varying from standard) • Current output • Cable type • Diameter.

APPLICATIONS FOR TELPRO FLEX-ANODE

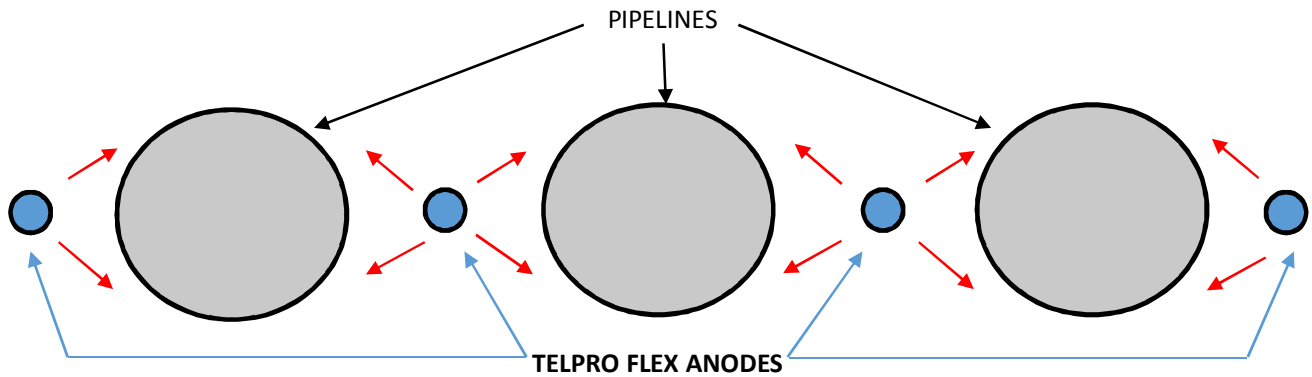

- PROTECT MULTIPLE PIPELINES IN A CORRIDOR
- EASY TO INSTALL ALONG WITH PIPE IN THE SAME TRENCH
- MULTIPLE LINEAR ANODES CAN BE DEPLOYED TO ENSURE EVEN CURRENT DISTRIBUTION
- POWER FEED CONNECTION ADVISED EVERY 100-150m MAXIMUM

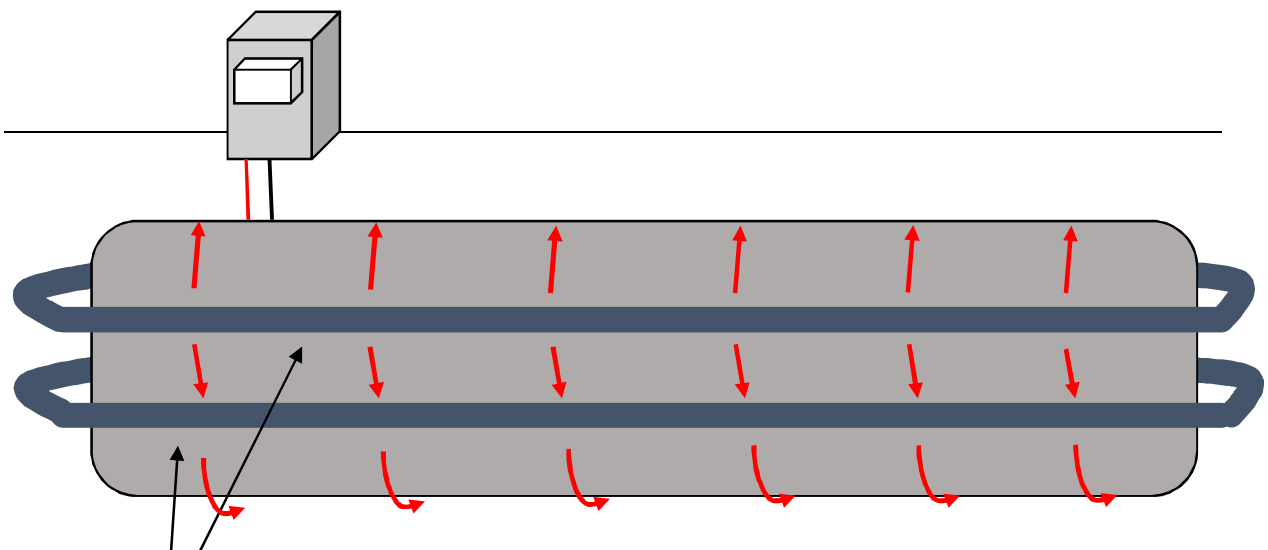

- TELPRO "FLEX ANODE" INSTALLED IN RINGS AROUND THE VESSEL / BULLET TANK
- BURIED VESSELS / BULLET TANKS CAN BE PROTECTED WITH DISTRIBUTED TUBULAR / CANISTER ANODES
- TELPRO FLEX ANODE CAN ALSO BE USED FOR EASE OF INSTALLATION AND EVEN CURRENT DISTRIBUTION
- "CLOSE ANODE" SYSTEMS ENSURE PROTECTION AND REMOVE ISOLATION COSTS.

FLEX-ANODE FOR UNDER TANKS DATA SHEET

Telpro Flex-Anodes are ideal for under-tank base plate protection. Anode loops are arranged in a concentric pattern as shown below with power feed cables routed back to a junction box. The Flex-Anode rating and spacing between loops can be adjusted according to the tank diameter, base plate coating, lifetime required and medium underneath the tank base. The Flex Anode can be provided pre-packaged in coke breeze backfill contained in a fabric sleeve or placed directly in low resistivity, soft, clean and washed sand.

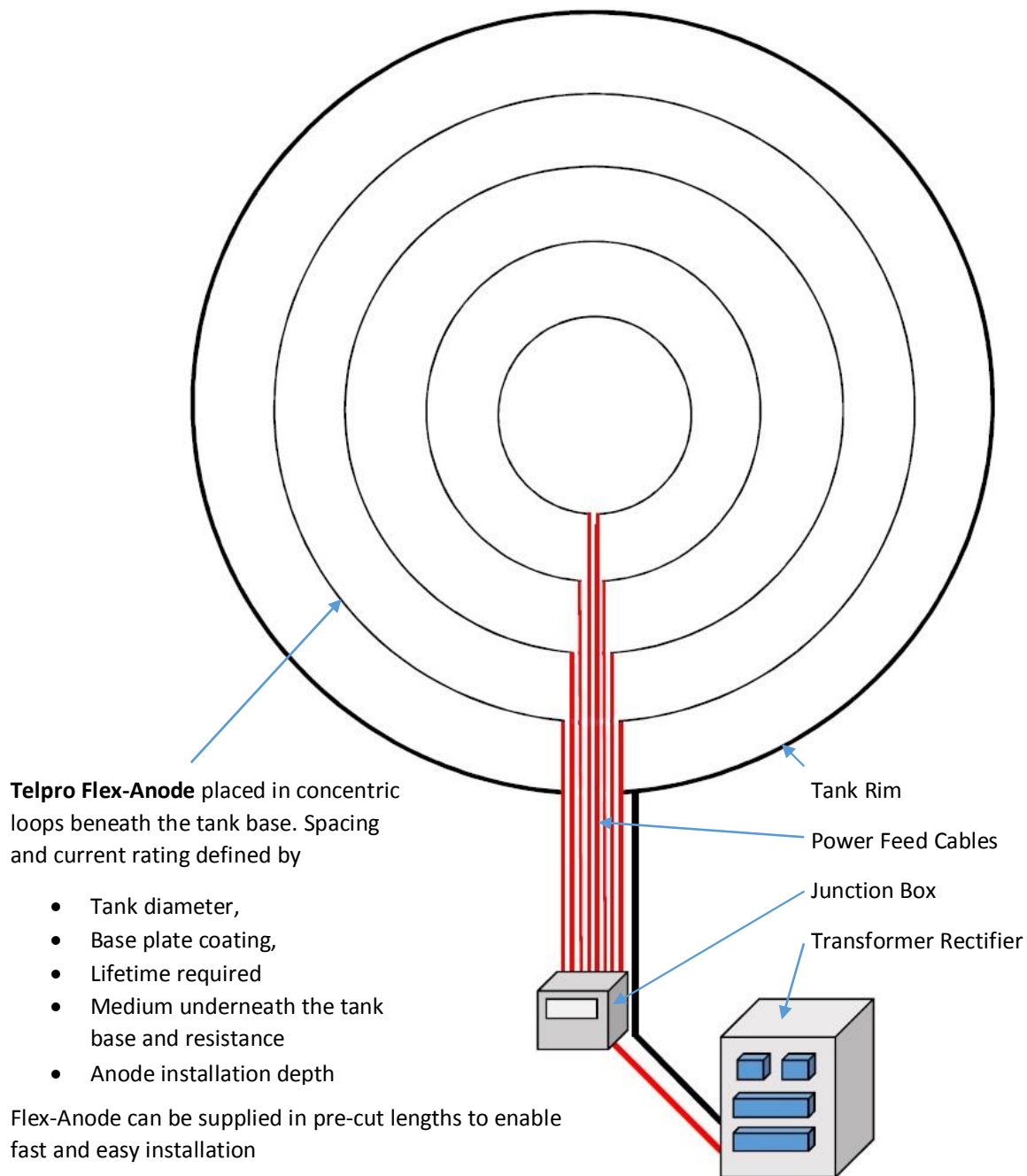

MESH STRIP ANODES DATA SHEET

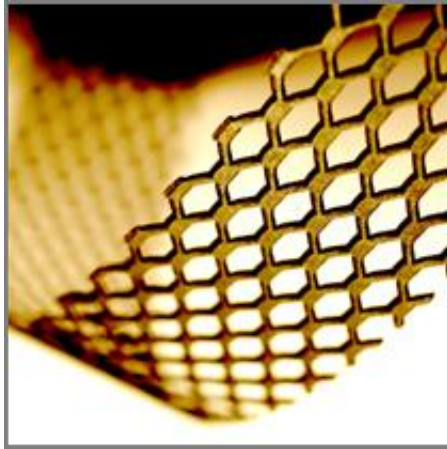

Titanium Electrode Products Companies, "TELPRO," are manufacturers of mixed metal oxide anodes for cathodic protection.

TELPRO Mesh Anodes are manufactured using a titanium expanded mesh substrate, which meets ASTM B265 Grade 1 or Grade 2, which has been coated with TELPRO Mixed Metal Oxide coating.

TELPRO MMO coating consists of IrO₂/Ta₂O₅ and is suitable for use in all cathodic protection applications. Because mixed metal oxide anodes have an extremely low consumption rate, the titanium substrate remains constant throughout the design life of the anode.

Based upon accelerated life testing, conducted by an independent laboratory, TELPRO MMO coating has been proven to be equivalent or superior to other mixed metal oxide coatings which are currently being used; a copy of this test report is available upon request.

APPLICATIONS

PIPELINES

STORAGE TANKS

IN PLANT PIPEWORK

VESSELS

Strict quality control procedures are followed throughout the entire coating process, to guarantee proper coating adhesion and loading. Also, TELPRO products are tested using an X-Ray Fluorescence Spectrometer, to ensure production of the highest quality product, which is fundamental in every step of the manufacturing process.

TELPRO's Canistered Mesh Anodes have been designed specifically to replace the massive 3" x 60" silicon iron anodes, typically used in horizontal and shallow ground beds. The TELPRO Mesh Strip Anode is 1.25" wide by 48" long and is rated at 5 amps, for a 20 year design life, in fine petroleum coke. TELPRO Mesh Strip Anodes can be packaged in galvanized steel canisters or flexible fabric sleeves, both of which are available in a wide variety of diameters and lengths.

ADVANTAGES

- LIGHTWEIGHT AND UNBREAKABLE
- ELECTRICAL CONNECTION FULLY ENCAPSULATED IN RESIN
- CONNECTION RESISTANCE LESS THAN 0.001 OHMS
- FINE PETROLEUM COKE USED TO ENSURE EFFICIENT CURRENT DISTRIBUTION FROM ANODE
- LOWER COST THAN 3" X 60" SILICON IRON ANODES
- LIGHTER WEIGHT MEANS LESS FREIGHT COST

USA OFFICE : PHONE 281 498 4727 FAX 281 498 4728 TOLL FREE 877 483 5776

UK OFFICE : PHONE 44 1453 845 718 FAX 44 1453 845 719

WEB : WWW.TELPROCOMPANIES.COM

EMAIL : MASH@TELPROCOMPANIES.COM / CATHY@TELPROCOMPANIES.COM / ANDREW@TELPROCOMPANIES.COM

MESH STRIP ANODES DATA SHEET

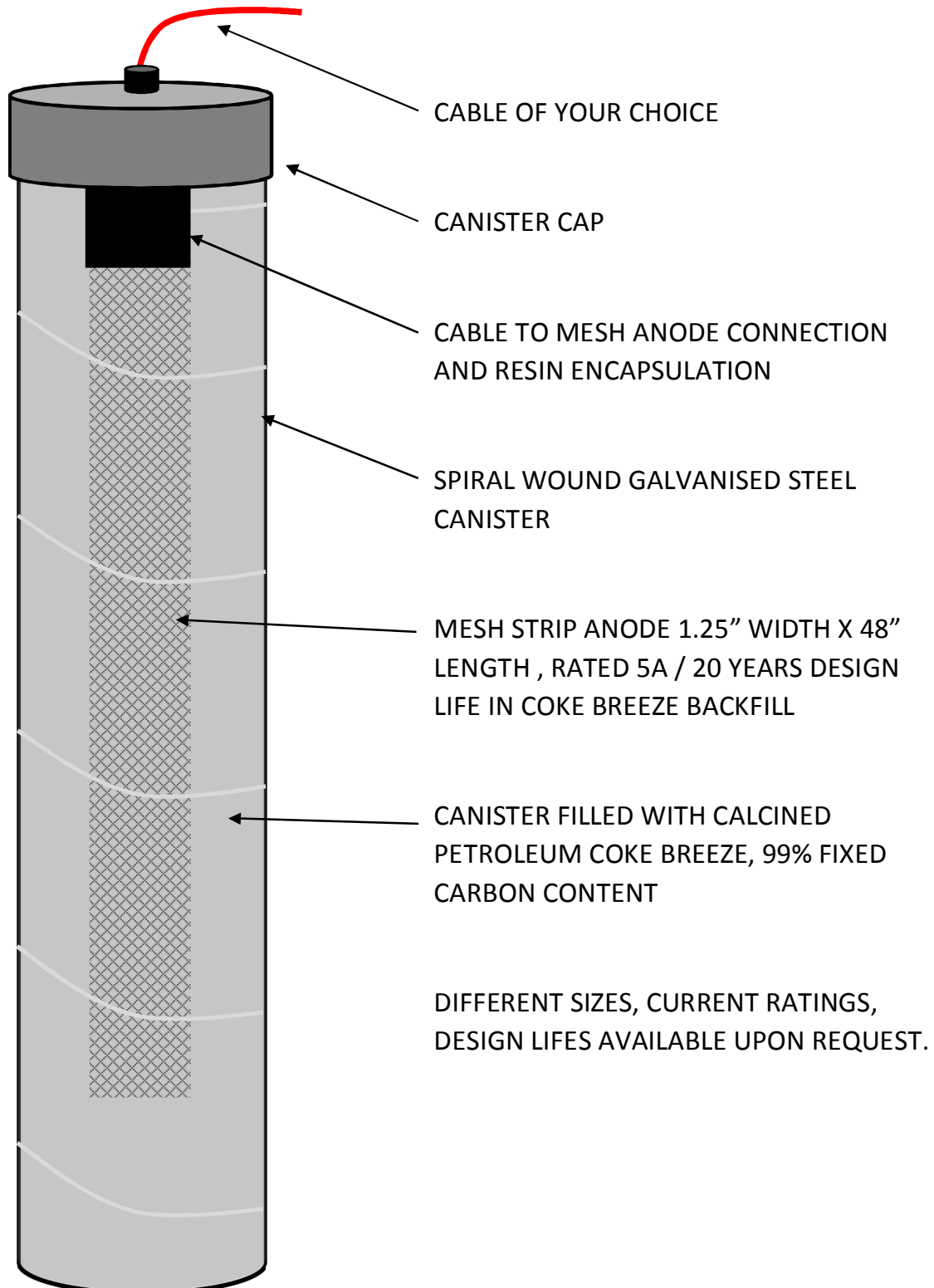

TELPRO ROD ANODES DATA SHEET



Titanium Electrode Products Companies, "TELPRO," are manufacturers of mixed metal oxide anodes for Cathodic protection.

TELPRO Rod Anodes are manufactured using titanium, which meets ASTM B348 Grade 1 or 2 standards, which has been coated with **TELPRO** Mixed Metal Oxide coating.

TELPRO MMO coating consists of IrO₂/Ta₂O₅ and is suitable for use in all cathodic protection applications. Because mixed metal oxide anodes have an extremely low consumption rate, the titanium substrate remains constant throughout the design life of the anode.

Based upon accelerated life testing, conducted by an independent laboratory, **TELPRO MMO** coating has been proven to be equivalent or superior to other mixed metal oxide coatings which are currently being used; a copy of this test report is available upon request.

Strict quality control procedures are followed throughout the entire coating process, to guarantee proper coating adhesion and loading. Also, **TELPRO** products are tested using an X-Ray Fluorescence Spectrometer, to ensure production of the highest quality product, which is fundamental in every step of the manufacturing process.

APPLICATIONS
TANK INTERNALS
PUMPS
CONDENSERS & WATER BOXES
PIPE INTERNALS
WATER INTAKES

TELPRO Rod Anodes are available in diameters of 1/8" (3.175mm), 1/4" (6.35mm), 1/2" (12.7mm), and 3/4" (19mm), as well as many other sizes which are all available upon request.

PERFORMANCE DATA AND RATINGS		
Environment	Maximum Current Density	Lifetime
CARBONACEOUS BACKFILL	4.6 A/ft ² (50 A/m ²)	20 years
CALCINED PETROLEUM COKE BACKFILL	9.3 A/ft ² (100 A/m ²)	20 years
FRESHWATER	9.3 A/ft ² (100 A/m ²)	20 years
BRACKISH WATER	9.3-27.8 A/ft ² (100-300 A/m ²)	20 years
SEAWATER	55.8 A/ft ² (600 A/m ²)	20 years

Lifetimes stated are nominal, we can supply Amps / life different to stated standards on request

USA OFFICE : PHONE 281 498 4727 FAX 281 498 4728 TOLL FREE 877 483 5776

UK OFFICE : PHONE 44 1453 845 718 FAX 44 1453 845 719

WEB : WWW.TELPROCOMPANIES.COM

EMAIL : MASH@TELPROCOMPANIES.COM / CATHY@TELPROCOMPANIES.COM / ANDREW@TELPROCOMPANIES.COM

TELPRO ROD ANODES DATA SHEET

LAYOUT OF A TYPICAL ROD ANODE ASSEMBLY.

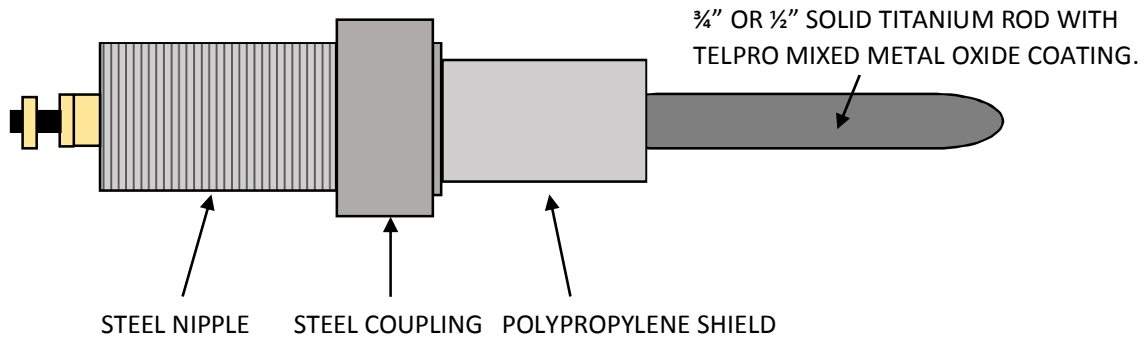

WATER BOX / TANK APPLICATIONS

"THRU WALL" ROD ANODE ASSEMBLY CAN BE EASILY INSTALLED, RETRIEVED AND REPLACED AT END OF SERVICE LIFE

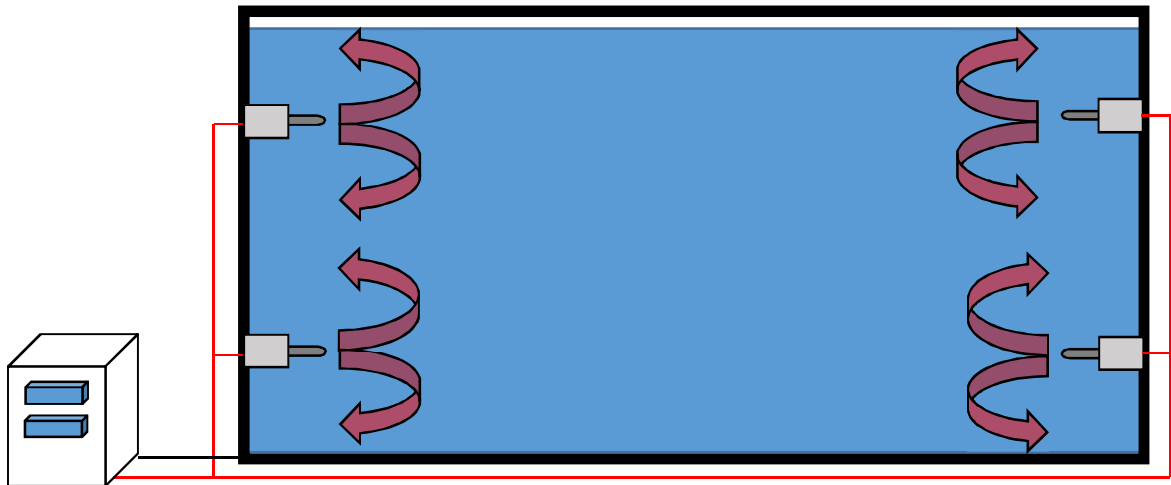

PIPELINE INTERNAL PROTECTION APPLICATIONS

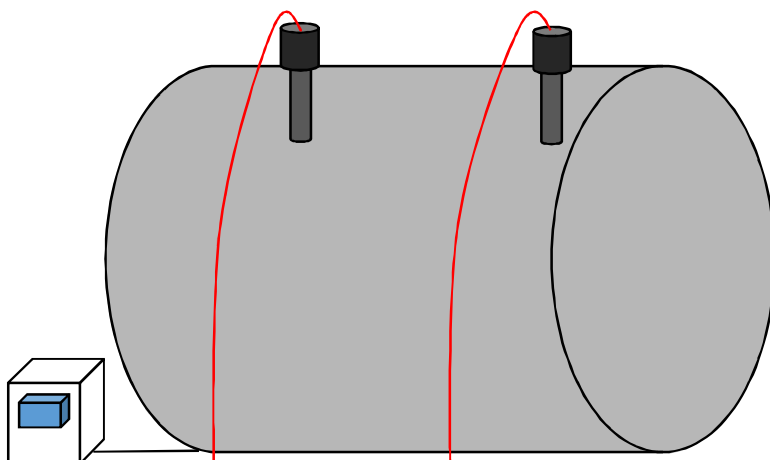

TELPRO ROD ANODES CAN BE FITTED
TO PROTECT PIPELINE INTERNALS.

TYPICALLY APPLIED TO LARGE
DIAMETER WATER COOLING INTAKE
PIPES

RETRIEVABLE ACCESS FITTINGS CAN
BE USED TO ENABLE INSPECTION,
REPAIR AND REPLACEMENT AT END
OF SERVICE LIFE

TELPRO DISC ANODES DATA SHEET



Titanium Electrode Products Companies, “**TELPRO**,” are manufacturers of mixed metal oxide anodes for Cathodic protection.

TELPRO Disc Anodes are manufactured using titanium, which meets ASTM B265 Grade 1 or 2 standards, which has been coated with **TELPRO** Mixed Metal Oxide coating.

TELPRO MMO coating consists of IrO₂/Ta₂O₅ and is suitable for use in all cathodic protection applications. Because mixed metal oxide anodes have an extremely low consumption rate, the titanium substrate remains constant throughout the design life of the anode.

Based upon accelerated life testing, conducted by an independent laboratory, **TELPRO MMO** coating has been proven to be equivalent or superior to other mixed metal oxide coatings which are currently being used; a copy of this test report is available upon request.

APPLICATIONS

MARINE STRUCTURES

PIPELINE INTERNALS

CONDENSERS & WATER BOXES

WATER INTAKES

Strict quality control procedures are followed throughout the entire coating process, to guarantee proper coating adhesion and loading. Also, **TELPRO** products are tested using an X-Ray Fluorescence Spectrometer, to ensure production of the highest quality product, which is fundamental in every step of the manufacturing process.

TELPRO Disc Anodes are available as standard in diameters of 6” (150mm) & 12” (300mm) as well as other sizes which are all available upon request.

PERFORMANCE DATA AND RATINGS

Environment	Maximum Current Density	Lifetime
CARBONACEOUS BACKFILL	4.6A/ft ² (50A/m ²)	20 years
CALCINED PETROLEUM COKE BACKFILL	9.3A/ft ² (100A/m ²)	20 years
FRESHWATER	9.3A/ft ² (100A/m ²)	20 years
BRACKISH WATER	9.3-27.8A/ft ² (100-300A/m ²)	20 years
SEAWATER	55.8A/ft ² (600A/m ²)	20 years

Lifetimes stated are nominal, we can supply Amps / life different to stated standards on request.

USA OFFICE : PHONE 281 498 4727 FAX 281 498 4728 TOLL FREE 877 483 5776

UK OFFICE : PHONE 44 1453 845 718 FAX 44 1453 845 719

WEB : WWW.TELPROCOMPANIES.COM

EMAIL : MASH@TELPROCOMPANIES.COM / CATHY@TELPROCOMPANIES.COM / ANDREW@TELPROCOMPANIES.COM

TELPRO DISC ANODES DATA SHEET

LAYOUT OF A TYPICAL DISC ANODE ASSEMBLY.

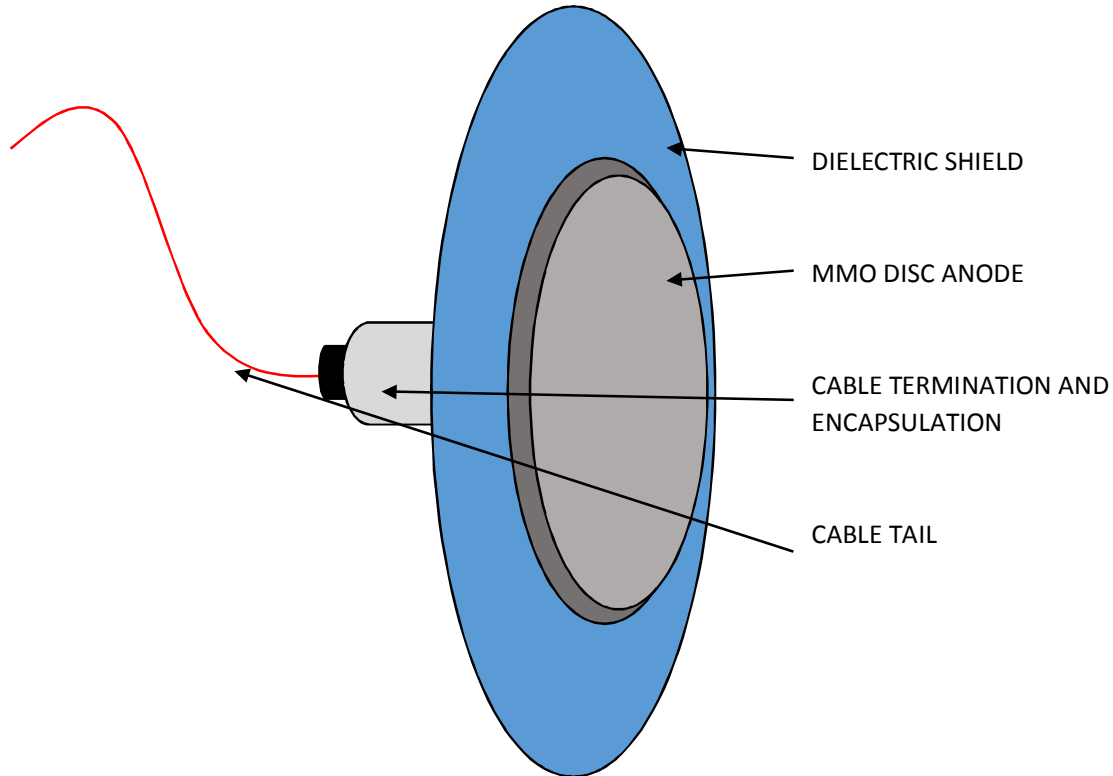

TYPICAL APPLICATIONS FOR DISC ANODES

JETTY / OFFSHORE STRUCTURE

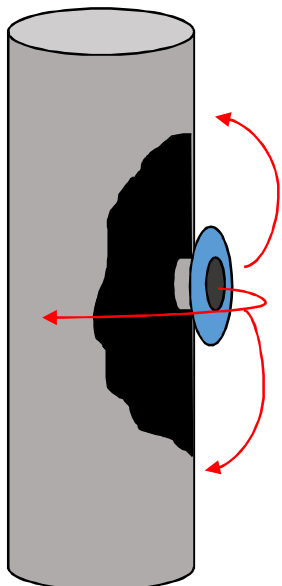

DISC ANODES CAN BE INSTALLED WITH A LOW PROFILE, PREVENTING DAMAGE FROM PASSING SHIPS / CRAFT.

EXTRA COATING MAY BE APPLIED TO THE STRUCTURE TO PREVENT LOCAL OVERPROTECTION

THRU WALL ANODE FOR CONDENSERS / WATER BOXES.

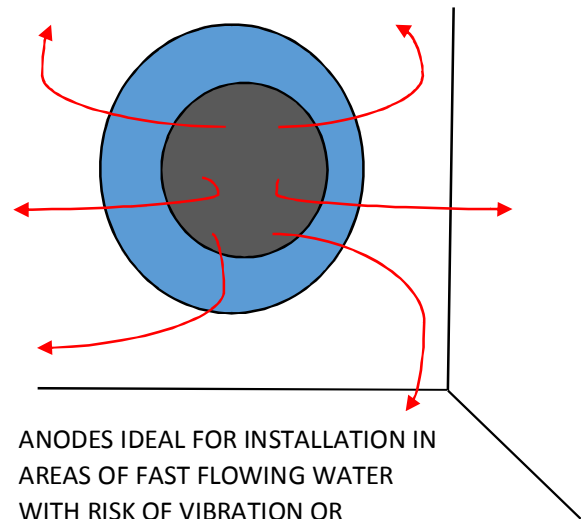

ANODES IDEAL FOR INSTALLATION IN AREAS OF FAST FLOWING WATER WITH RISK OF VIBRATION OR SHEARING DAMAGE.

TELPRO “TEL-TANK” ANODE DATA SHEET

TYPICAL “TEL TANK” SYSTEM LAYOUT

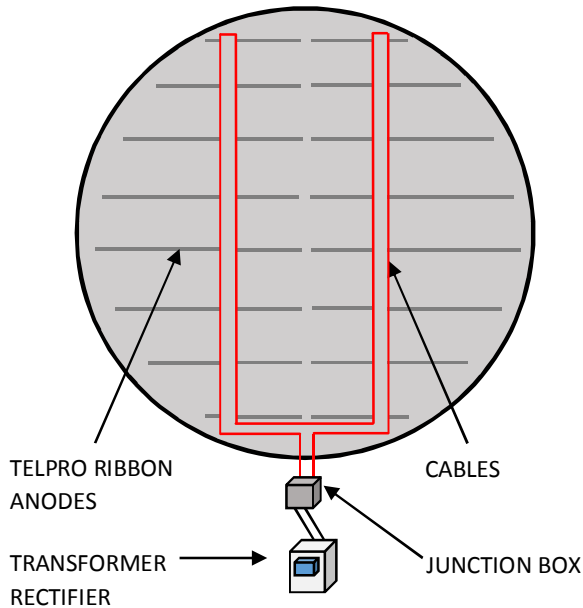

TELPRO TEL-TANK Anode Assemblies are designed for ease of installation and cost savings. TEL-TANK Anode Assemblies use **TELPRO MMO Ribbon Anodes** assembled on HMWPE Cable. **TELPRO Ribbon** is manufactured using titanium to ASTM B265 Grade 1 specifications, which has been coated with **TELPRO Mixed Metal Oxide coating**.

TELPRO MMO coating consists of IrO₂/Ta₂O₅ and is suitable for use in all cathodic protection applications. Because mixed metal oxide anodes have an extremely low consumption rate, the titanium substrate remains constant throughout the design life of the anode.

TELPRO TEL-TANK Anodes are assembled to meet customer requirements. Each **TEL-TANK Anode System** is factory assembled and ready for installation. No field welds are required. All anode-to-cable connections are sealed using a moisture resistant epoxy, which has been helium tested to ensure the quality of the seal and provide long lasting protection.

Based upon accelerated life testing, conducted by an independent laboratory, **TELPRO MMO coating** has been proven to be equivalent or superior to other mixed metal oxide coatings which are currently being used; a copy of this test report is available upon request.

Strict quality control procedures are followed throughout the entire coating process, to guarantee proper coating adhesion and loading. Also, **TELPRO** products are tested using an X-Ray Fluorescence Spectrometer, to ensure production of the highest quality product, which is fundamental in every step of the manufacturing process.

TO RECEIVE A QUOTATION FOR TEL-TANK SYSTEMS PLEASE SPECIFY AS FOLLOWS,

- | | |
|---|---|
| <ul style="list-style-type: none"> Quantity of Tanks Diameter of Tanks Required Design Life Operating Temperature of Tank | <ul style="list-style-type: none"> Current Density to be Applied to Tank Base Details of External Base Plate Coating Installation Depth Of Anode Layer Cable Distance to Junction Box Location. |
|---|---|

CURRENT OUTPUT OF RIBBON IN FINE SAND

12.8mA/ft (42mA/m) When operating at an anode current density of 0.278 A/ft² (3A/m²)

DESIGN LIFE

50 years plus when operating at an anode current density of 0.278 A/ft² (3A/m²)

Lifetimes stated are nominal, we can supply Amps / life different to stated standards on request.

USA OFFICE : PHONE 281 498 4727 FAX 281 498 4728 TOLL FREE 877 483 5776

UK OFFICE : PHONE 44 1453 845 718 FAX 44 1453 845 719

WEB : WWW.TELPROCOMPANIES.COM

EMAIL : MASH@TELPROCOMPANIES.COM / CATHY@TELPROCOMPANIES.COM / ANDREW@TELPROCOMPANIES.COM

SAWTOOTH RIBBON ANODES DATA SHEET



Titanium Electrode Products Companies, "TELPRO," are manufacturers of mixed metal oxide anodes for cathodic protection.

Telpro Sawtooth Ribbon Anodes are a new product development for **Telpro**. We corrugate a flat ribbon to increase its overall surface area to obtain a higher current output. **Telpro Sawtooth Ribbon Anode** is manufactured using titanium which meets ASTM B265 Grade 1 which has been coated with **Telpro Mixed Metal Oxide Coating**.

Telpro MMO coating consists of IrO₂/Ta₂O₅ and is suitable for use in all cathodic protection applications. Because mixed metal oxide anodes have a very low consumption rate the titanium substrate remains constant throughout the design life of the anode.

Telpro Sawtooth Ribbon Anode provides greater flexibility because the ribbons are laid on the concrete surface in parallel lines with the separation between ribbons adjusted to give the required per square meter output. The maximum spacing between the anodes will vary according to the concrete cover over the rebar, but is usually up to 14" (350mm). The approach is price competitive compared to using a mesh product, especially where you have areas of increased steel density where you simply put more ribbon together.

APPLICATIONS

STEEL REBAR IN CONCRETE
EXTERNAL TANK BASES

SAWTOOTH RIBBON SPECIFICATIONS

0.50" (12.7mm) MATERIAL

NOMINAL DIMENSIONS -	0.50" (12.7mm) Wide x 0.16" (4mm) Thick
SURFACE AREA -	0.0573m ² /m
CURRENT OUTPUT IN CONCRETE -	6.3mA/m (at industry recommended maximum current density of 110mA/m ²)

0.25" (6.35mm) MATERIAL

NOMINAL DIMENSIONS -	0.25" (6.35mm) Wide x 0.24" (0.6mm) Thick
SURFACE AREA -	0.0286m ² /m
CURRENT OUTPUT IN CONCRETE -	3.15mA/m (at industry recommended maximum current density of 110mA/m ²)

Lifetimes stated are nominal, we can supply Amps / life different to stated standards on request.

USA OFFICE : PHONE 281 498 4727 FAX 281 498 4728 TOLL FREE 877 483 5776

UK OFFICE : PHONE 44 1453 845 718 FAX 44 1453 845 719

WEB : WWW.TELPROCOMPANIES.COM

EMAIL : MASH@TELPROCOMPANIES.COM / CATHY@TELPROCOMPANIES.COM / ANDREW@TELPROCOMPANIES.COM

SAWTOOTH RIBBON ANODES DATA SHEET

Strict quality control procedures are followed throughout the entire coating process, to guarantee proper coating adhesion and loading. Also, **TELPRO** products are tested using an X-Ray Fluorescence Spectrometer, to ensure production of the highest quality product, which is fundamental in every step of the manufacturing process.

TYPICAL APPLICATIONS FOR SAWTOOTH RIBBON ANODES

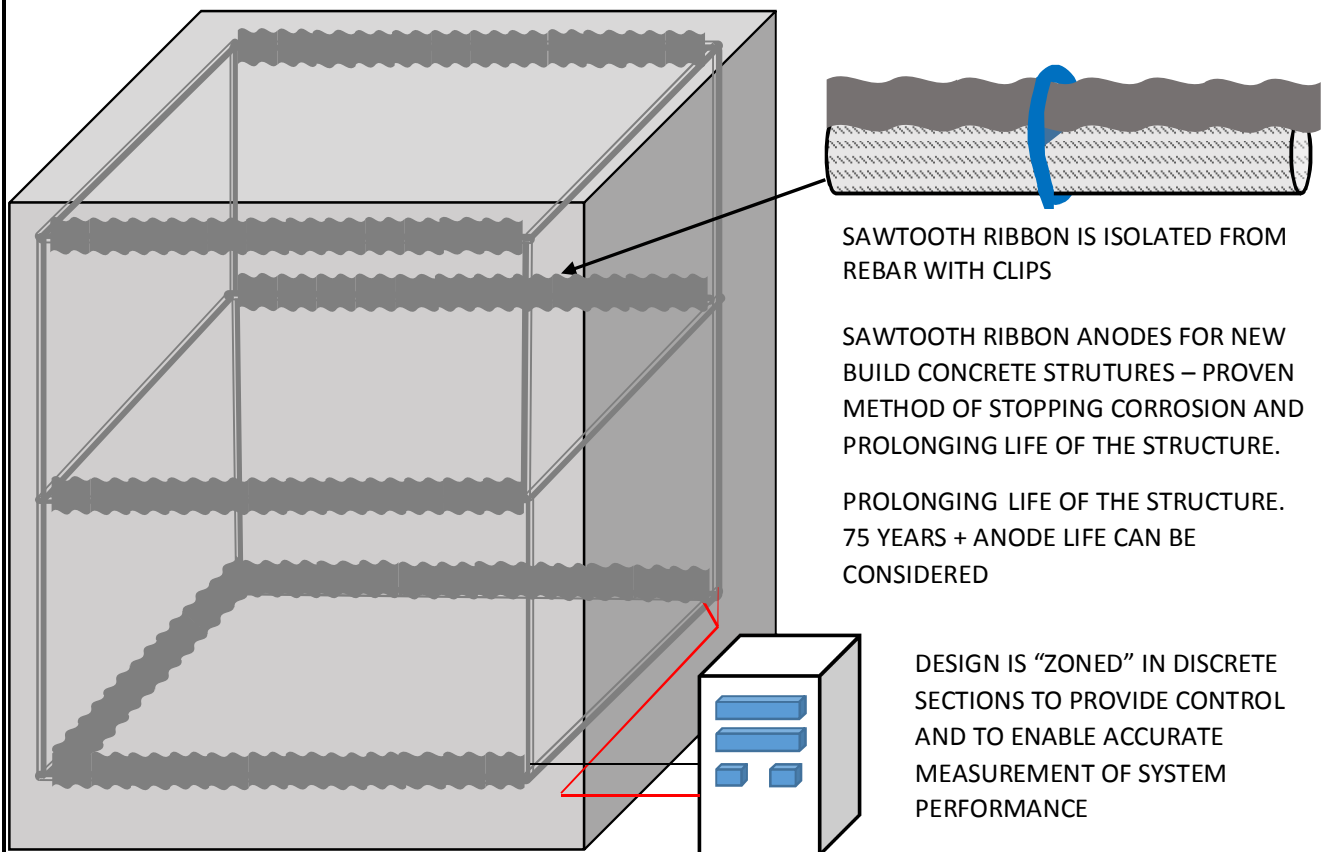

ADVANTAGES OF SAWTOOTH RIBBON ANODE

- LOWER INTERNAL RESISTANCE THAN RIBBON MESH ANODES
- BETTER CONTACT WITH CONCRETE / MORTAR
- LESS LIKELY TO DEVELOP VOIDS AROUND THE ANODE WHEN CASTING WHICH CAN FILL WITH MOISTURE AND LEAD TO CORROSION OF REBAR

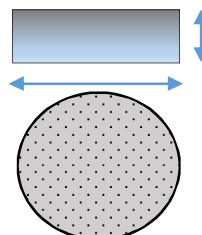
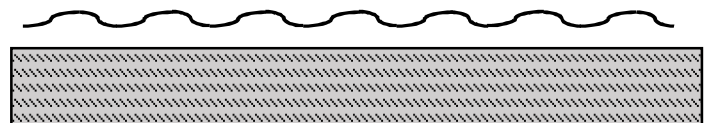

0.5" (12.7mm) Width
0.25" (6mm) Height



MANUFACTURERS OF MMO AND
PLATINIZED TITANIUM ELECTRODES

POINT SOURCE DISCRETE ANODES DATA SHEET

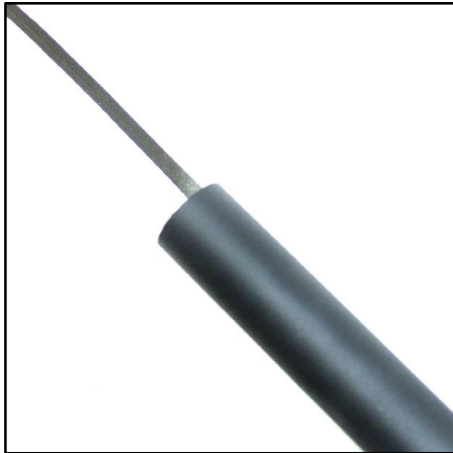

Titanium Electrode Products Companies, "TELPRO," are manufacturers of mixed metal oxide anodes for cathodic protection.

TELPRO Mixed Metal Oxide Activated Tubular Point Source Anodes are manufactured using titanium, which meets ASTM B338 Grade 1 or Grade 2 standards, which has been coated with **TELPRO Mixed Metal Oxide** coating.

TELPRO MMO coating applied to the titanium substrate has been designed for use in all cathodic protection applications. **TELPRO** coating consists of IrO₂/Ta₂O₅ and is suitable for use in soils, freshwater, brackish water and seawater. Because mixed metal oxide anodes have an extremely low consumption rate, the titanium substrate used remains constant throughout the design life of the anode.

APPLICATIONS
STEEL REBAR IN CONCRETE
STEEL FRAME BUILDINGS

Based upon accelerated life testing, conducted by an independent laboratory, **TELPRO MMO** coating has been proven to be equivalent or superior to other mixed metal oxide coatings which are currently being used; a copy of this test report is available upon request.

Strict quality control procedures are followed throughout the entire coating process, to guarantee proper coating adhesion and loading. Also, **TELPRO** products are tested using an X-Ray Fluorescence Spectrometer, to ensure production of the highest quality product, which is fundamental in every step of the manufacturing process.

TELPRO MMO Oxide Activated Tubular Point Source Anodes can be self-gas venting or supplied with venting holes, plastic end-caps and a PVC venting tube. These anodes can also be supplied with a spot welded titanium conductor bar, typically manufactured of titanium ribbon, 0.25" (6.35mm) by 0.025" (.635mm), which can be either coated or uncoated, and of a length appropriate to suit project requirements.

The current output of the anode is calculated by multiplying the anode surface area x design current density, which typically can vary 110mA/m² to 900mA/m², subject to design factors such as gas venting, acidic attack on concrete, life of system, etc. Normal Design Life for the point source anode is typically 50 plus years when operating at an anode current density of 900mA/m². Coating loading can be adjusted for any combination of current output and design life. Lifetimes are nominal we can supply amps / life different to stated standards on request. Working Environment: Evolution of O₂, Cl₂ or combination of both.

USA OFFICE : PHONE 281 498 4727 FAX 281 498 4728 TOLL FREE 877 483 5776

UK OFFICE : PHONE 44 1453 845 718 FAX 44 1453 845 719

WEB : WWW.TELPROCOMPANIES.COM

EMAIL : MASH@TELPROCOMPANIES.COM / CATHY@TELPROCOMPANIES.COM / ANDREW@TELPROCOMPANIES.COM

POINT SOURCE DISCRETE ANODES DATA SHEET

LAYOUT OF POINT SOURCE ANODE PRODUCT

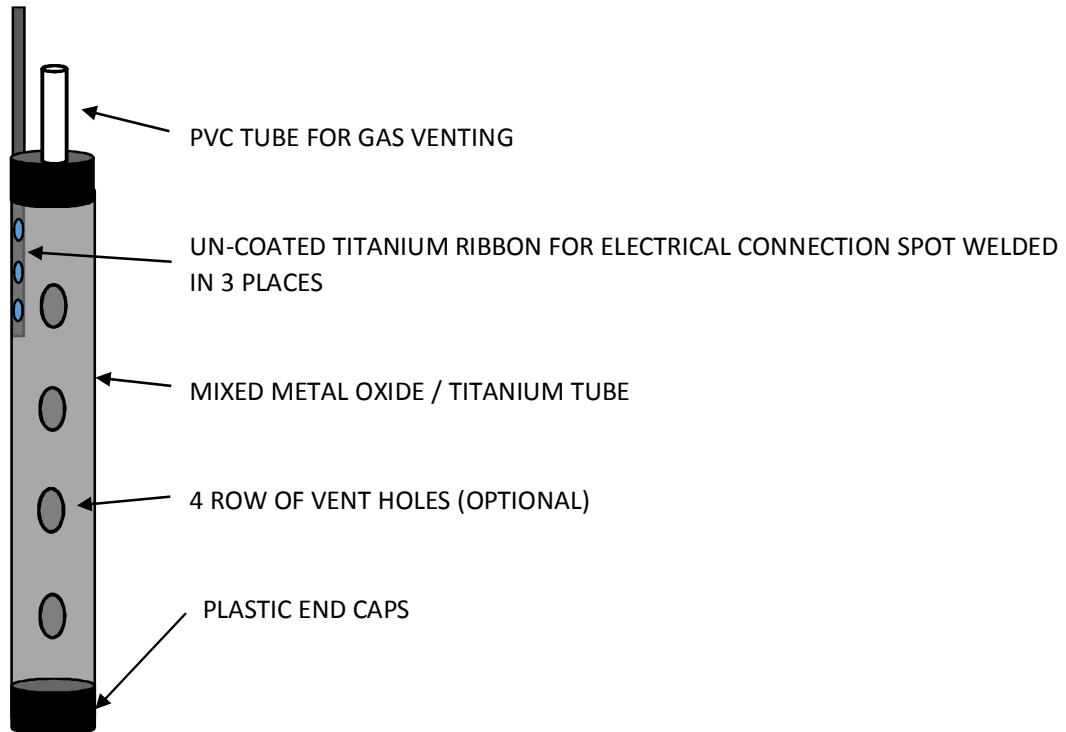

TYPICAL INSTALLATION OF POINT SOURCE ANODES.

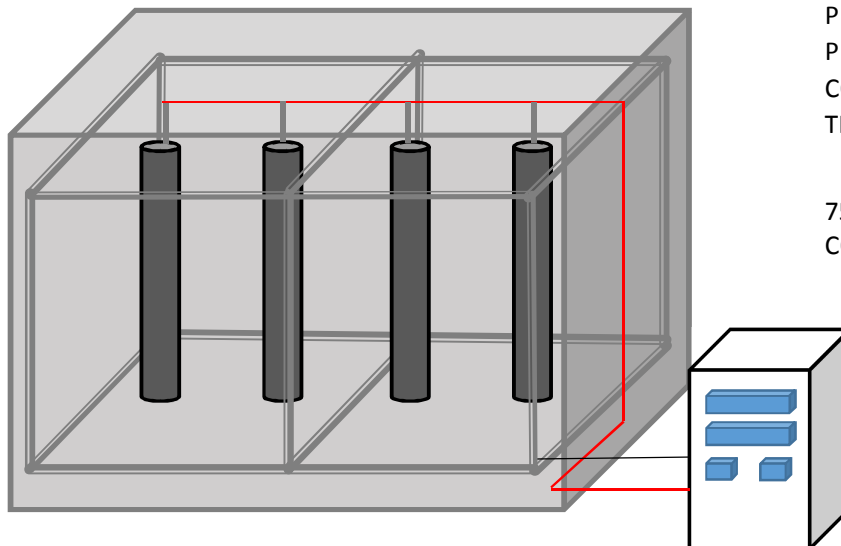

POINT SOURCE DISCRETE ANODES FOR NEW BUILD AND RETROFIT OF CATHODIC PROTECTION TO CONCRETE STRUTURES – PROVEN METHOD OF STOPPING CORROSION AND PROLONGING LIFE OF THE STRUCTURE.

75 YEARS + ANODE LIFE CAN BE CONSIDERED

DESIGN IS “ZONED” IN DISCRETE SECTIONS TO PROVIDE CONTROL AND TO ENABLE ACCURATE MEASUREMENT OF SYSTEM PERFORMANCE