

## TELPRO TUBULAR ANODES DATA SHEET



Titanium Electrode Products Companies, "TELPRO," are manufacturers of mixed metal oxide anodes for cathodic protection.

**TELPRO Tubular Anodes** are manufactured using titanium, which meets ASTM B338 Grade 1 or Grade 2 standards, which has been coated with **TELPRO** Mixed Metal Oxide coating.

**TELPRO MMO** coating consists of IrO<sub>2</sub>/Ta<sub>2</sub>O<sub>5</sub> and is suitable for use in all cathodic protection applications. Because mixed metal oxide anodes have an extremely low consumption rate, the titanium substrate remains constant throughout the design life of the anode.

Based upon accelerated life testing, conducted by an independent laboratory, **TELPRO MMO** coating has been proven to be equivalent or superior to other mixed metal oxide coatings which are currently being used; a copy of this test report is available upon request.

APPLICATIONS
CANISTERED ANODES
ABOVE GROUND STORAGE TANKS
UNDERGROUND STORAGE TANKS
WATER STORAGE TANKS
HORIZONTAL GROUNDBEDS
TUBULAR AND SHEET PILES
VERTICAL GROUNDBEDS
DEEP WELL ANODE GROUNDBEDS

Strict quality control procedures are followed throughout the entire coating process, to guarantee proper coating adhesion and loading. Also, **TELPRO** products are tested using an X-Ray Fluorescence Spectrometer, to ensure production of the highest quality product, which is fundamental in every step of the manufacturing process.

### PERFORMANCE DATA AND RATINGS

COKE, SOIL AND FRESH WATER	CURRENT OUTPUT	DESIGN LIFE
3/4" x 48" (19mm x 1,220mm)	7 Amps	20 years
1" x 19.7" (25mm x 500mm)	4 Amps	20 years
1" x 39.4" (25mm x 1,000mm)	8 Amps	20 years
1" x 48" (25mm x 1,220mm)	3.5 Amps *	20 years
1" x 60" (25mm x 1,500mm)	4.5 Amps *	20 years
1.25" x 48" (32mm x 1,220mm)	12 Amps	20 years

\* Current outputs are de-rated for use in metallurgical coke breeze - 50Am<sup>2</sup>

**USA OFFICE :** PHONE 281 498 4727 FAX 281 498 4728 TOLL FREE 877 483 5776

**UK OFFICE :** PHONE 44 1453 845 718 FAX 44 1453 845 719

**WEB :** [WWW.TELPROCOMPANIES.COM](http://WWW.TELPROCOMPANIES.COM)

**EMAIL :** [MASH@TELPROCOMPANIES.COM](mailto:MASH@TELPROCOMPANIES.COM) / [CATHY@TELPROCOMPANIES.COM](mailto:CATHY@TELPROCOMPANIES.COM)

## TELPRO TUBULAR ANODES DATA SHEET

SEAWATER	CURRENT OUTPUT	DESIGN LIFE
3/4" x 48" (19mm x 1,220mm)	45 Amps	20 years
1" x 19.7" (25mm x 500mm)	25 Amps	20 years
1" x 39.4" (25mm x 1,000mm)	50 Amps	20 years
1.25" x 48" (32mm x 1,220mm)	75 Amps	20 years
ENVIRONMENT	MAX CURRENT DENSITY	LIFETIME
CARBONACEOUS BACKFILL	4.6A/ft <sup>2</sup> (50A/m <sup>2</sup> )	20 years
CALCINED PETROLEUM BACKFILL	9.3A/ft <sup>2</sup> (100A/m <sup>2</sup> )	20 years
FRESHWATER	9.3A/ft <sup>2</sup> (100A/m <sup>2</sup> )	20 years
BRACKISH WATER	9.3-27.8A/ft <sup>2</sup> (100-300A/m <sup>2</sup> )	20 years
SEAWATER	55.8A/ft <sup>2</sup> (600A/m <sup>2</sup> )	20 years

**Lifetimes stated are nominal, we can supply Amps / life different to stated standards on request**

### TYPICAL APPLICATIONS FOR TUBULAR ANODES

#### HORIZONTAL GROUNDBEDS

PROTECTION OF CROSS COUNTRY PIPELINES

ANODES TYPICALLY INSTALLED IN A TRENCH WITH COKE BACKFILL

IDEAL FOR AREAS OF LOW RESISTIVITY / NO ACCESS / R.O.W. ISSUES

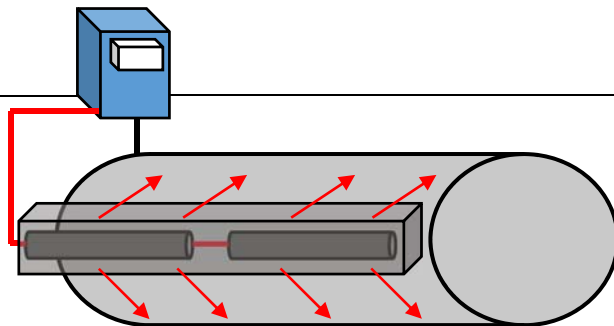

#### DEEPWELL GROUNDBEDS

PROTECTION OF PIPELINES / WELL CASINGS

ANODES INSTALLED IN COKE BREEZE COLUMN OR BELOW WATER TABLE LEVEL

USED IN AREAS OF HIGH SURFACE RESISTIVITY AND/ OR ACCESS / R.O.W. LIMITATIONS

ACTIVE WELL AREA LINED WITH PERFORATED CASING

