

TELPRO ROD ANODES DATA SHEET



Titanium Electrode Products Companies, "TELPRO," are manufacturers of mixed metal oxide anodes for Cathodic protection.

TELPRO Rod Anodes are manufactured using titanium, which meets ASTM B348 Grade 1 or 2 standards, which has been coated with **TELPRO** Mixed Metal Oxide coating.

TELPRO MMO coating consists of IrO₂/Ta₂O₅ and is suitable for use in all cathodic protection applications. Because mixed metal oxide anodes have an extremely low consumption rate, the titanium substrate remains constant throughout the design life of the anode.

Based upon accelerated life testing, conducted by an independent laboratory, **TELPRO MMO** coating has been proven to be equivalent or superior to other mixed metal oxide coatings which are currently being used; a copy of this test report is available upon request.

Strict quality control procedures are followed throughout the entire coating process, to guarantee proper coating adhesion and loading. Also, **TELPRO** products are tested using an X-Ray Fluorescence Spectrometer, to ensure production of the highest quality product, which is fundamental in every step of the manufacturing process.

APPLICATIONS
TANK INTERNALS
PUMPS
CONDENSERS & WATER BOXES
PIPE INTERNALS
WATER INTAKES

TELPRO Rod Anodes are available in diameters of 1/8" (3.175mm), 1/4" (6.35mm), 1/2" (12.7mm), and 3/4" (19mm), as well as many other sizes which are all available upon request.

PERFORMANCE DATA AND RATINGS		
Environment	Maximum Current Density	Lifetime
CARBONACEOUS BACKFILL	4.6 A/ft ² (50 A/m ²)	20 years
CALCINED PETROLEUM COKE BACKFILL	9.3 A/ft ² (100 A/m ²)	20 years
FRESHWATER	9.3 A/ft ² (100 A/m ²)	20 years
BRACKISH WATER	9.3-27.8 A/ft ² (100-300 A/m ²)	20 years
SEAWATER	55.8 A/ft ² (600 A/m ²)	20 years

Lifetimes stated are nominal, we can supply Amps / life different to stated standards on request

USA OFFICE : PHONE 281 498 4727 FAX 281 498 4728 TOLL FREE 877 483 5776

UK OFFICE : PHONE 44 1453 845 718 FAX 44 1453 845 719

WEB : WWW.TELPROCOMPANIES.COM

EMAIL : MASH@TELPROCOMPANIES.COM / CATHY@TELPROCOMPANIES.COM

TELPRO ROD ANODES DATA SHEET

LAYOUT OF A TYPICAL ROD ANODE ASSEMBLY.

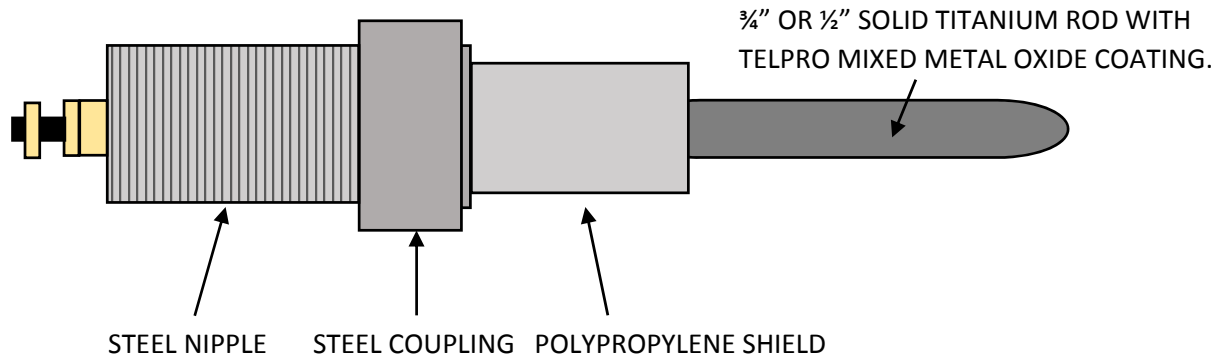

WATER BOX / TANK APPLICATIONS

"THRU WALL" ROD ANODE ASSEMBLY CAN BE EASILY INSTALLED, RETRIEVED AND REPLACED AT END OF SERVICE LIFE

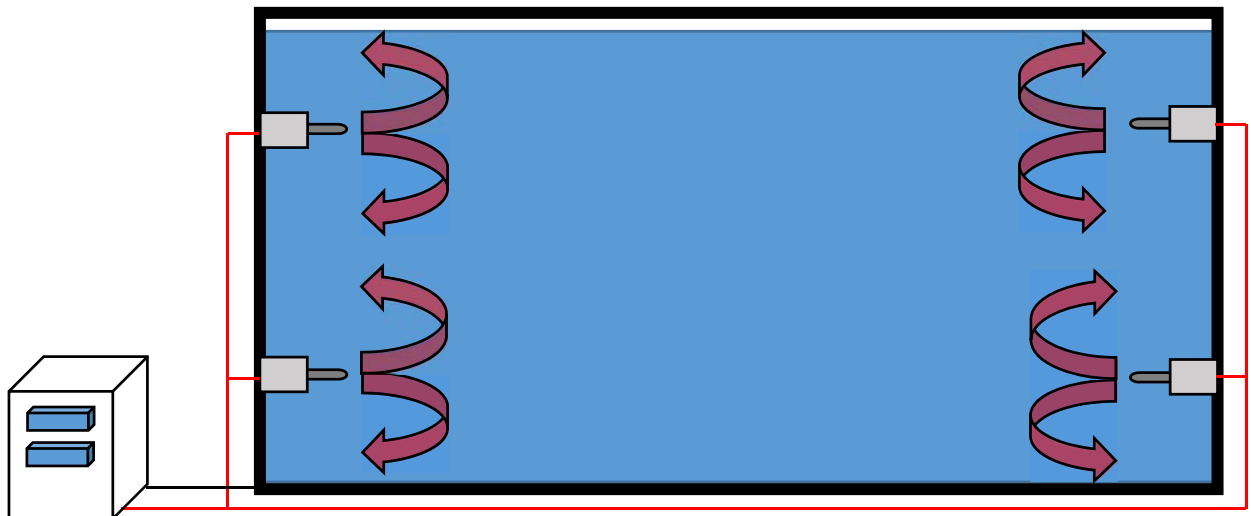

PIPELINE INTERNAL PROTECTION APPLICATIONS

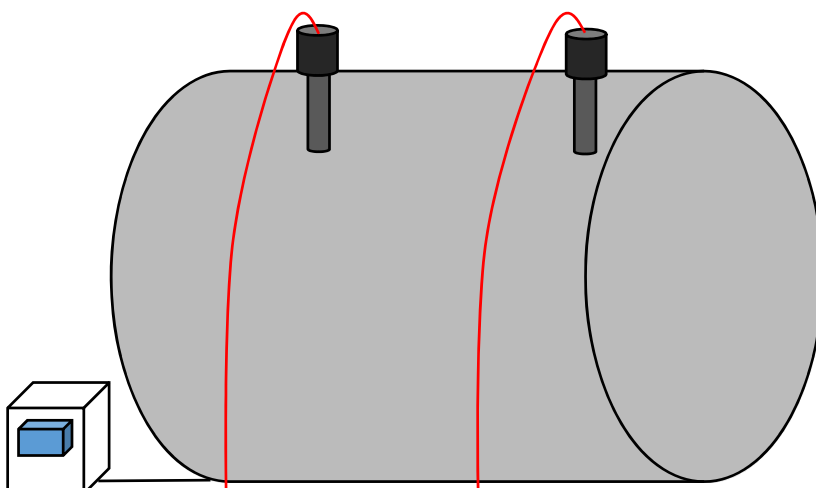

TELPRO ROD ANODES CAN BE FITTED TO PROTECT PIPELINE INTERNALS.

TYPICALLY APPLIED TO LARGE DIAMETER WATER COOLING INTAKE PIPES

RETRIEVABLE ACCESS FITTINGS CAN BE USED TO ENABLE INSPECTION, REPAIR AND REPLACEMENT AT END OF SERVICE LIFE